

FPH 014

PUNTE PER FORATRICI FORO CIECO

Boring bits - blind holes
Dübellochbohrer
Brocas para taladros ciego

Diamante Diamant Diamond

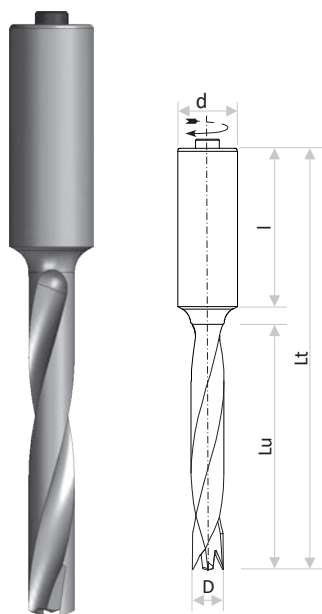

- AFFILATURA PIATTA SENZA INCISIONI -
Perfect cut without engraving

INFORMAZIONI TECNICHE / TECHNICAL INFORMATIONS

• Adatto a medi e grandi lotti / Useful for medium and large batch

MACCHINE / MACHINES

• Pantografi - CNC - Punto / Punto - CNC Machines
• Macchine speciali con inserimento ad attacco cilindrico
Special machines

APPLICAZIONI / APPLICATIONS

• Foratura / Boring

MATERIALI LAVORABILI / MACHINABLE MATERIALS

• Truciolare / Chipboard • MDF • Laminati / Laminated
• Materiale abrasivi / Abrasive Materials • Legni / Wood

Punta speciale e innovativa costruita in HW integrale per l'esecuzione di fori ciechi su qualsiasi materiale

Special, innovative drill bit made of integral HW for executing blind holes on any material

Spezieller und innovativer Stift aus Vollhartmetall zur Ausführung von Sacklöchern bei jedem Material

Broca especial e innovadora de HW integral para realizar cortes ciegos en cualquier material



CODICE CODE		D mm	Lu mm	Lt mm	ATTACCO - SHANK d mm l mm		Z	R	ROTAZ. ROTAT.
FPH01401	FPH01413	4	27	57,5	10	30	2	2	R/L
FPH01402	FPH01414	5	27	57,5	10	30	2	2	R/L
FPH01403	FPH01415	6	27	57,5	10	30	2	2	R/L
FPH01404	FPH01416	7	27	57,5	10	30	2	2	R/L
FPH01405	FPH01417	8	27	57,5	10	30	2	2	R/L
FPH01406	FPH01418	10	27	57,5	10	30	2	2	R/L
FPH01407	FPH01419	4	35	70	10	30	2	2	R/L
FPH01408	FPH01420	5	35	70	10	30	2	2	R/L
FPH01409	FPH01421	6	35	70	10	30	2	2	R/L
FPH01410	FPH01422	7	35	70	10	30	2	2	R/L
FPH01411	FPH01423	8	35	70	10	30	2	2	R/L
FPH01412	FPH01424	10	35	70	10	30	2	2	R/L