

# DAF 462

## FRESA ELICOIDALI Z2+2

Helical router for strong feeding Z2+2  
Spiralförmig Z2+2 Schaftfräser für starken Vorschub  
Fresas helicoidales de alto avance Z2+2

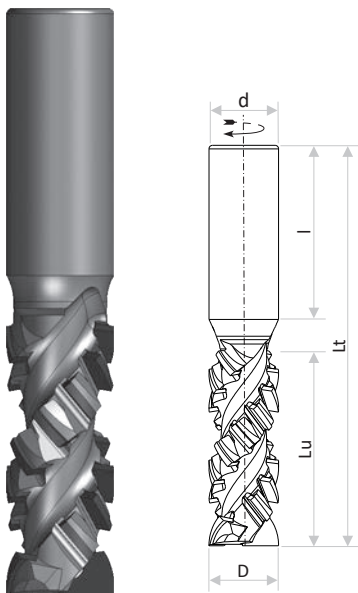

### INFORMAZIONI TECNICHE / TECHNICAL INFORMATION

- Riaffilabile / Resharpener 6-8 volte / times
- n° di giri/RPM 18.000-20.000 rpm
- Avanzamento / Feed rate 10-12 m / min

### MACCHINE / MACHINES

- Pantografi - CNC - Punto - Punto / CNC Machines
- Macchine speciali con inserimento ad attacco cilindrico  
Special machines

### APPLICAZIONI / APPLICATIONS

- Foratura / Boring • Contornatura / Contouring
- Scanalatura / Grooving
- Ottima finitura su entrambi i lati (sopra e sotto)  
Good finishing on both sides
- Adatto a medi e grandi lotti / Useful for medium and large batch

### MATERIALI LAVORABILI / MACHINABLE MATERIALS

- Truciolare / Chipboard • MDF • Laminati / Laminated
- Materiale abrasivi / Abrasive Materials • Legno / Wood

Fresa elicoidale Z2+2 assiale 45° per forte avanzamento

45° axis Z2+2 helical milling cutter for powerful feeding

45° Axial Z2 + 2 Spiralförmigfräser für hohen Vorschub

Fresa helicoidal Z2+2 axial 45° para altas velocidades de avance



	CODICE CODE	D mm	Lu mm	Lt mm	ATTACCO - SHANK d mm l mm		Z	ROTAZ. ROTAT.	PLACCHE - TIPS n° Forante	
	Z2 F2 H4	DAF462-01	20	24	85	20	50	2	R	8
DAF462-02		20	29	90	20	50	2	R	10	DP
DAF462-03		20	34	95	20	50	2	R	12	DP
DAF462-04		20	39	100	20	50	2	R	14	DP
DAF462-05		20	44,5	105	20	50	2	R	16	DP
DAF462-06		20	49	110	20	50	2	R	18	DP
DAF462-07		20	54	115	20	50	2	R	20	DP

DIAMANTE Diamond Diamant Diamante