

DAF 336

FRESA PER FORARE E CONTORNARE

Router for drilling and contouring
Schaftfräser zum bohren und schneiden
Fresa para taladrar y contornear

Diamante

Diamant

Diamond

DIAMANTE

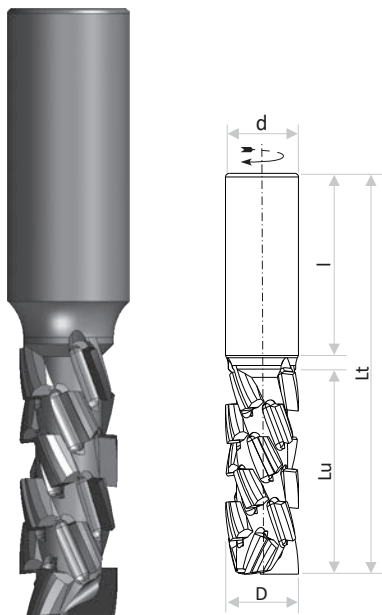

INFORMAZIONI TECNICHE / TECHNICAL INFORMATIONS

- Riaffilabile / Resharpener 6-8 volte / times
- n° di giri/RPM 18.000-20.000 rpm
- Avanzamento / Feed rate 10-12 m / min

MACCHINE / MACHINES

- Pantografi - CNC - Punto - Punto / CNC Machines
- Macchine speciali con inserimento ad attacco cilindrico
Special machines

APPLICAZIONI / APPLICATIONS

- Foratura / Boring • Contornatura / Contouring
- Scanalatura / Grooving
- Ottima finitura su entrambi i lati (sopra e sotto)
Good finishing on both sides
- Adatto a medi e grandi lotti / Useful for medium and large batch

MATERIALI LAVORABILI / MACHINABLE MATERIALS

- Truciolare / Chipboard • MDF • Laminati / Laminated
- Materiale abrasivi / Abrasive Materials • Legno / Wood

Fresa in Z3+3 per forte avanzamento

Z3+3 milling cutter for powerful feeding

Z3-+3-Fräser für hohen Vorschub

Fresa en Z3+3 para altas velocidades de avance



	CODICE CODE	D	Lu	Lt	ATTACCO - SHANK		Z	ROTAZ. ROTAT.	PLACCHE - TIPS	
		mm	mm	mm	d mm	l mm			n°	Forante
Z3 F6 H4	DAF33601	20	28	80	20	50	3	R	8	DP
	DAF33602	20	37	90	20	50	3	R	11	DP
	DAF33603	20	46	100	20	50	3	R	14	DP
	DAF33604	20	55	110	20	50	3	R	17	DP
	DAF33605	25	28	90	25	55	3	R	8	DP
	DAF33606	25	37	100	25	55	3	R	11	DP
	DAF33607	25	46	110	25	55	3	R	14	DP
	DAF33608	25	55	120	25	55	3	R	17	DP
	DAF33609	25	64	130	25	55	3	R	20	DP