

DAF 329

FRESA PER SPIANARE CON SISTEMA VORTEX

Planing cutter with Vortex System
Planfräser mit Vortex System
Fresa para planear con sistema Vortex

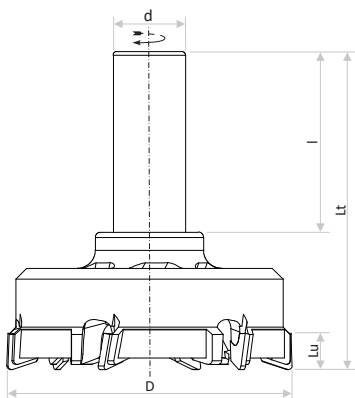
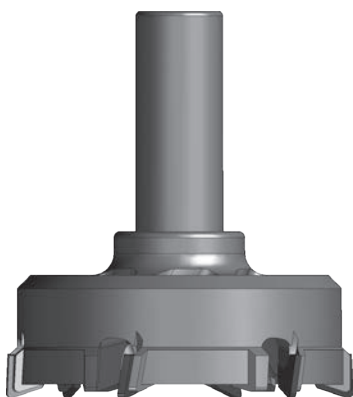

INFORMAZIONI TECNICHE / TECHNICAL INFORMATIONS

- Riaffilabile / Resharpener 5-6 volte / times
- n° di giri/RPM 12.000-14.000 rpm
- Avanzamento / Feed rate 8-10 m / min

MACCHINE / MACHINES

- Pantografi - CNC - Punto - Punto / CNC • Machines
- Macchine speciali con inserimento ad attacco cilindrico
Special machines

APPLICAZIONI / APPLICATIONS

- Svuotamenti e spianatura / Emptying and Planing
- Adatto a medi e grandi lotti / Useful for medium and large batch

MATERIALI LAVORABILI / MACHINABLE MATERIALS

- Truciolare / Chipboard • MDF • Laminati / Laminated
- Materiale abrasivi / Abrasive Materials • Legno / Wood

Fresa per spianare in diamante realizzata con un sistema speciale che facilita l'eliminazione delle polveri di lavorazione, con tutti i benefici per produttività, durata dell'utensile e manutenzione.

Diamond planing cutter featuring a special system that facilitates the elimination of machining dust, with all the benefits for productivity, tool life and maintenance.

Diamant-Schaftfräser zum planen mit einem speziellen System realisiert, dass die Beseitigung von Bearbeitungspulver erleichtert mit allen Vorteilen für die Produktivität, Werkzeugsdauer und Wartung.

Fresa en diamante para planear, fabricada con un sistema especial que facilita la eliminación del polvo de mecanizado, con todas las ventajas para la productividad, vida útil de la herramienta y mantenimiento.



CODICE CODE	D mm	Lu mm	Lt mm	ATTACCO - SHANK d mm l mm	Z	ROTAZ. ROTAT.	PLACCHE - TIPS n°
DAF32901	40	10	88	20 50	4	R	4
DAF32902	60	10	88	20 50	4	R	4
DAF32903	80	10	88	20 50	6	R	6

DIAMANTE Diamant Diamant Diamant