

DAF 325

FRESA PER SMUSSI A 45°

Router for bevels 45°
Schaftfräser für Fasen 45°
Fresa para bisel 45°

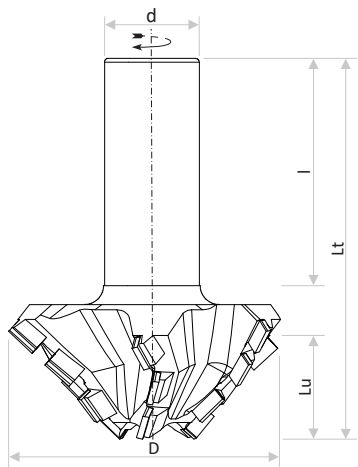
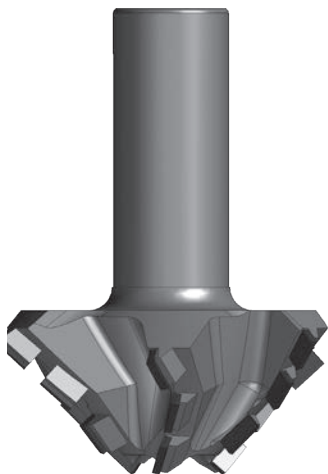

INFORMAZIONI TECNICHE / TECHNICAL INFORMATIONS

- Riaffilabile / Resharpening 6-8 volte / times
- n° di giri/RPM 12.000-14.000
- Avanzamento / Feed rate 10-12 m / min

MACCHINE / MACHINES

- Pantografi - CNC - Punto - Punto / CNC Machines
- Macchine speciali con inserimento ad attacco cilindrico
Special machines

APPLICAZIONI / APPLICATIONS

- Smussi a 45° / 45° Beveling
- Ottima finitura su entrambi i lati (sopra e sotto)
Good finishing on both sides
- Adatto a medi e grandi lotti / Useful for medium and large batch

MATERIALI LAVORABILI / MACHINABLE MATERIALS

- Truciolare / Chipboard • MDF • Laminati / Laminated
- Materiale abrasivi / Abrasive Materials • Legno / Wood

Fresa con taglio frazionato per migliore finitura e avanzamento

Milling cutter with fractional cut for better finish and feed

Fräser mit Teilschnitt für bessere Oberflächengüte und besseren Vorschub

Fresa con corte fraccionado para un mejor acabado y avance



DIAMANTE Diamant Diamond Diamante

	CODICE	MATERIALE	D	Lu	Lt	ATTACCO - SHANK		Z	ROTAZ.	PLACCHE - TIPS
	CODE	MATERIAL	mm	mm	mm	d mm	l mm		ROTAT.	n° Forante
Z3 F6 H4	DAF32501	ACCIAIO	80	28	100	25	60	3+3	R	18