

DAF 281

FRESA PER FORARE E CONTORNARE

Routers for drilling and contouring
Schaftfräser zum bohren und schneiden
Fresas para taladrar y contornear

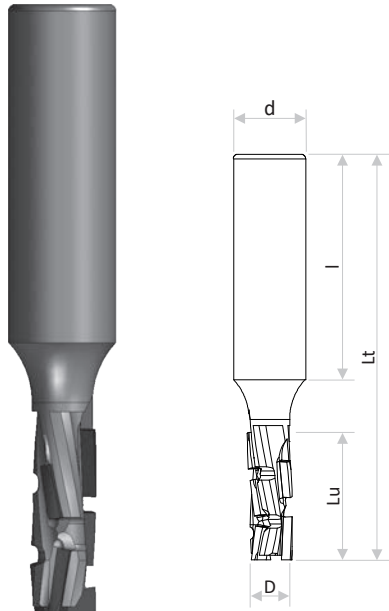

INFORMAZIONI TECNICHE / TECHNICAL INFORMATIONS

- Riaffilabile / Resharpener 2-3 volte / times
- n° di giri/RPM 18.000-20.000 rpm
- Avanzamento / Feed rate 6-8 m / min

MACCHINE / MACHINES

- Pantografi - CNC - Punto - Punto / CNC Machines
- Macchine speciali con inserimento ad attacco cilindrico
Special machines

APPLICAZIONI / APPLICATIONS

- Foratura / Boring • Contornatura / Contouring
- Scanalatura / Grooving
- Ottima finitura su entrambi i lati (sopra e sotto)
Good finishing on both sides
- Adatto a medi e grandi lotti / Useful for medium and large batch

MATERIALI LAVORABILI / MACHINABLE MATERIALS

- Truciolare / Chipboard • MDF • Laminati / Laminated
- Materiale abrasivi / Abrasive Materials • Legno / Wood

Fresa Z2 con costruzione adatta anche a diametri piccoli

Z2 milling cutter with construction suitable for small diameters

Z2-Fräser mit einer auch für kleine Durchmesser geeignete Konstruktion

Fresa Z2 con construcción adecuada para diámetros pequeños



	CODICE CODE	D	L1	Lu	Lt	ATTACCO - SHANK		Z	ROTAZ. ROTAT.	PLACCHE - TIPS	
		mm	mm	mm	mm	d mm	l mm			n°	Forante
Z2 F3 H2,5	DAF28121	10	21,5	30	80	12	40	2	R	7	HW
	DAF28123	12	32	36	85	12	40	2	R	8	HW
	DAF28101	20	27	30	96	20	50	2	R	7	HW
	DAF28103	20	32	36	96	20	50	2	R	8	HW
	DAF28105	20	42	44	104	20	50	2	R	10	HW
	DAF28107	20	52	54	112	20	50	2	R	12	HW
	DAF28109	20	65	69,5	125	25	50	2	R	16	HW