

FRESA PER BATTUTE A TAGLIANTI ALTERNI

Tonguing cutter with alternate teeth
 Falzfräser mit wechselnden Schneiden
 Fresa para galges con dientes alternados

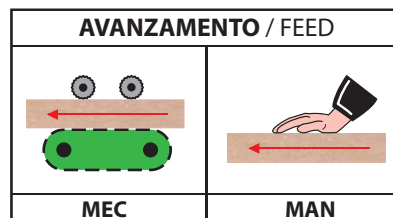
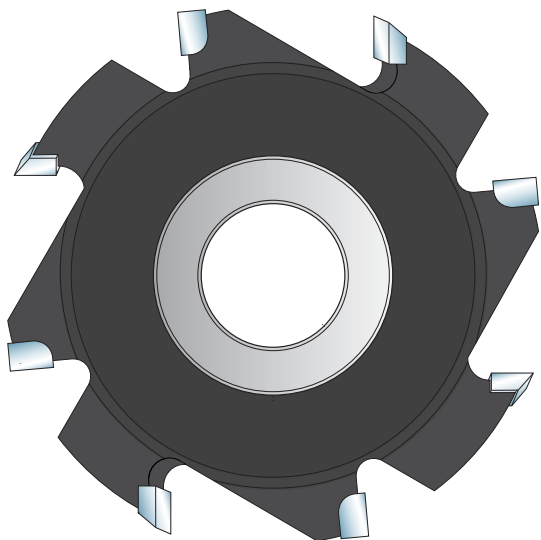

CODICE CODE	B mm	d mm	Z	DIAMETRI / DIAMETERS				
				D=120	D=140	D=160	D=180	D=200
SB12001	20	35 / 40	4 + 4					
SB12002	25	35 / 40	4 + 4					
SB12003	30	35 / 40	4 + 4					
SB12004	35	35 / 40	4 + 4					
SB12005	40	35 / 40	4 + 4					
SB12006	50	35 / 40	4 + 4					
SB12007	60	35 / 40	4 + 4					

ESEMPI DI LAVORAZIONE Working Example

