

## TESTA CON PROFILO SAGOMATO Z4 / Z6 / Z8 - COLTELLO ZIGRINATO S=8-10mm

Profiled cutter head Z4 / Z6 / Z8

- Knurled Knife S=8/10 mm

Profiliertes Messerkopf Z4 / Z6 / Z8

- Gerändeltesmesser S=8/10 mm

Cabezal perfilado Z4 / Z6 / Z8

- Cuchilla estriada S=8/10 mm

### I COLTELLI NON SONO INCLUSI NELLA TESTA

Knives are not included with the heads

Die Köpfe werden ohne Messer geliefert

Los cabezales vienen sin cuchillas

CODICE CODE	MATERIALE MATERIAL	D mm	B mm	d mm	Z	PESO Kg
PT09001	ACCIAIO	122	40	40	4	2,91
PT09002	ACCIAIO	122	60	40	4	4,37
PT09003	ACCIAIO	122	80	40	4	5,82
PT09004	ACCIAIO	122	100	40	4	7,28
PT09005	ACCIAIO	122	130	40	4	9,46
PT09006	ACCIAIO	122	150	40	4	10,91
PT09007	ACCIAIO	122	180	40	4	13,10
PT09008	ACCIAIO	122	200	40	4	14,55
PT09009	ACCIAIO	122	230	40	4	16,73
PT09010	ACCIAIO	137	40	40	4	3,87
PT09011	ACCIAIO	137	60	40	4	5,80
PT09012	ACCIAIO	137	80	40	4	7,74
PT09013	ACCIAIO	137	100	40	4	9,67
PT09014	ACCIAIO	137	130	40	4	12,57
PT09015	ACCIAIO	137	150	40	4	14,50
PT09016	ACCIAIO	137	180	40	6	16,59
PT09017	ACCIAIO	137	200	40	6	18,43
PT09018	ACCIAIO	137	230	40	6	21,19
PT09019	ACCIAIO	152	60	40	6	7,13
PT09020	ACCIAIO	152	100	40	6	11,89
PT09021	ACCIAIO	152	130	40	6	15,45
PT09022	ACCIAIO	152	150	40	6	17,83
PT09023	ACCIAIO	152	180	40	6	21,39
PT09024	ACCIAIO	152	200	40	6	23,77
PT09025	ACCIAIO	152	230	40	6	27,34
PT09026	ACCIAIO	160	60	40	8	7,74
PT09027	ACCIAIO	160	100	40	8	12,89
PT09028	ACCIAIO	160	130	40	8	16,76
PT09029	ACCIAIO	160	150	40	8	19,34
PT09030	ACCIAIO	160	180	40	8	23,21
PT09031	ACCIAIO	160	200	40	8	25,79
PT09032	ACCIAIO	160	230	40	8	29,65

DISTINTA BASE / Bill of Materials											
DESCRIZIONE DESCRIPTION	DIMENSIONI mm	CODICE CODE	CODICE PT090								
			01-10	02-11	03-12	04-13	05-14	06-15	07-16	08-17	09-18
Cuneo / Wedge	38 x 24 x 10	CU132	4	/	/	/	/	/	/	/	/
Cuneo / Wedge	58 x 24 x 10	CU133	/	4	/	/	/	/	/	/	/
Cuneo / Wedge	78 x 24 x 10	CU134	/	/	4	/	/	/	/	/	/
Cuneo / Wedge	98 x 24 x 10	CU135	/	/	/	4	/	/	/	/	/
Cuneo / Wedge	128 x 24 x 10	CU136	/	/	/	/	4	/	/	/	/
Cuneo / Wedge	148 x 24 x 10	CU137	/	/	/	/	/	4	/	/	/
Cuneo / Wedge	178 x 24 x 10	CU139	/	/	/	/	/	/	4	/	/
Cuneo / Wedge	198 x 24 x 10	CU140	/	/	/	/	/	/	/	4	/
Cuneo / Wedge	228 x 24 x 10	CU142	/	/	/	/	/	/	/	/	4
Vite per Cuneo / Wedge's Screw	M10 x 20	VT022	8	8	12	12	16	16	20	20	24
Chiave per Cuneo / Wedge's Key	Esagonale 5	CH005	1	1	1	1	1	1	1	1	1

DISTINTA BASE / Bill of Material															
DESCRIZIONE DESCRIPTION	DIMENSIONI mm	CODICE CODE	CODICE PT090												
			19	20	21	22	23	24	25	26	27	28	29	30	31
Cuneo / Wedge	58 x 24 x 10	CU133	6	/	/	/	/	/	/	8	/	/	/	/	/
Cuneo / Wedge	98 x 24 x 10	CU135	/	6	/	/	/	/	/	/	8	/	/	/	/
Cuneo / Wedge	128 x 24 x 10	CU136	/	/	6	/	/	/	/	/	/	8	/	/	/
Cuneo / Wedge	148 x 24 x 10	CU137	/	/	/	6	/	/	/	/	/	/	8	/	/
Cuneo / Wedge	178 x 24 x 10	CU139	/	/	/	/	6	/	/	/	/	/	/	8	/
Cuneo / Wedge	198 x 24 x 10	CU140	/	/	/	/	/	6	/	/	/	/	/	/	8
Cuneo / Wedge	228 x 24 x 10	CU142	/	/	/	/	/	/	6	/	/	/	/	/	/
Vite per Cuneo / Wedge's Screw	M10 x 20	VT022	12	18	24	24	30	30	36	16	24	32	32	40	40
Chiave per Cuneo / Wedge's Key	Esagonale 5	CH005	1	1	1	1	1	1	1	1	1	1	1	1	1

**COLTELLI ORDINABILI / Knives to be ordered**

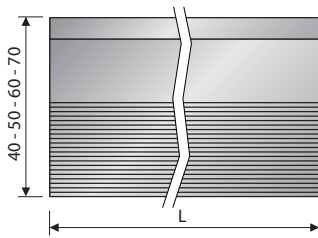

**CR**

Vedi pag. 393 / see page 393

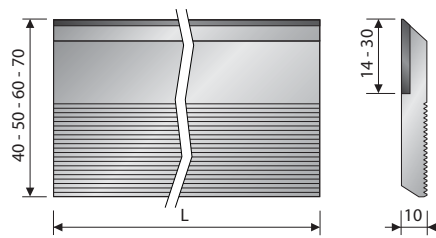

**CRW**

Vedi pag. 394 / see page 394

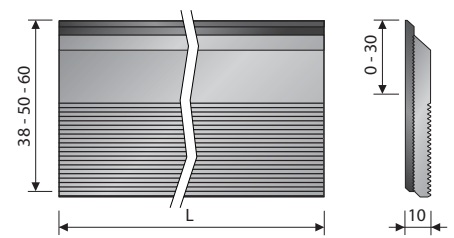

**Super Pack**

Vedi pag. 395 / see page 395

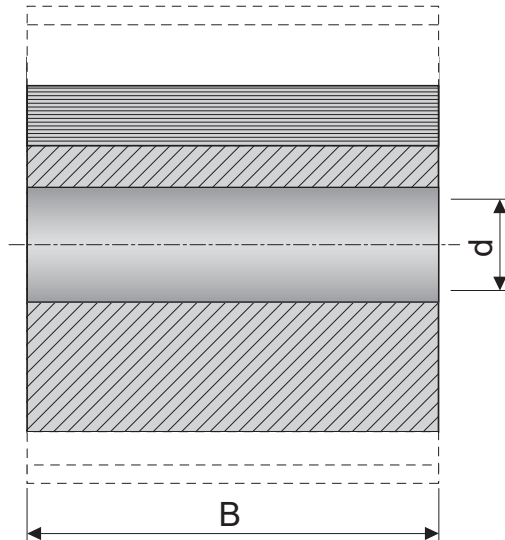
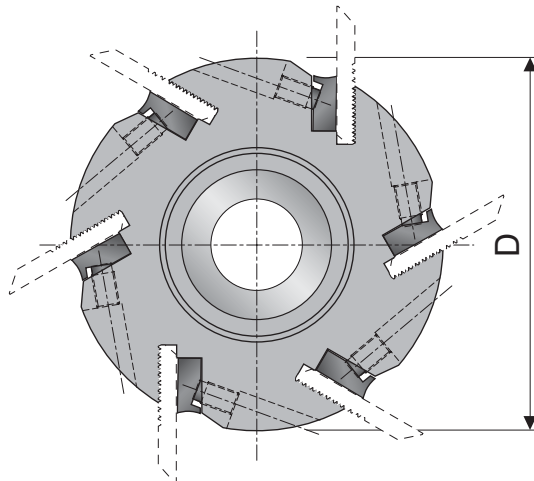

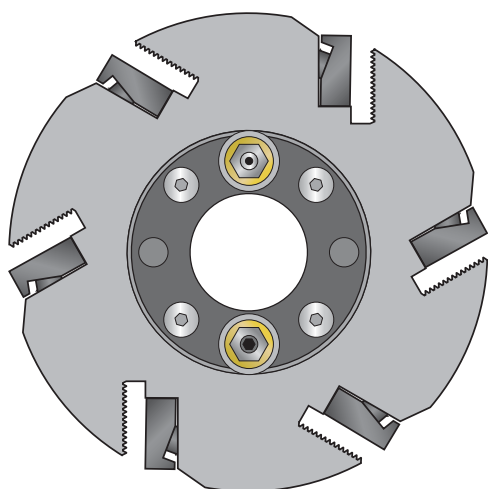



## TESTA HYDRO CON PROFILO SAGOMATO Z4 / Z6 / Z8 - COLTELLO ZIGRINATO SP=8-10mm

Profiled hydro cutter head Z4 / Z6 / Z8  
 - Knurled Knife S=8/10 mm  
 Profilierter Hydro Messerkopf Z4 / Z6 / Z8  
 - Gerändeltesmesser S=8/10 mm  
 Cabezal hidro perfilado Z4 / Z6 / Z8  
 - Cuchilla estriada S=8/10 mm

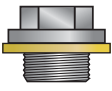
**I COLTELLI NON SONO INCLUSI NELLA TESTA**  
 Knives are not included with the heads  
 Die Köpfe werden ohne Messer geliefert  
 Los cabezales vienen sin cuchillas

RICAMBI ORDINABILI SPARE PARTS	
	<b>VT024 E-31</b>
VALVOLA DI INGRASSAGGIO GREASER VALVE	
	<b>VT025 E-32</b>
VITE DI SFIATO EXHAUST SCREW	
	<b>GOR01 C-134</b>
GUARNIZIONE PER BUSSOLA O-RING'S BUSH	

CODICE CODE	MATERIALE MATERIAL	D mm	B mm	d mm	Z	PESO Kg
PT09101	ACCIAIO	122	60	40	4	4,37
PT09102	ACCIAIO	122	100	40	4	7,28
PT09103	ACCIAIO	122	130	40	4	9,46
PT09104	ACCIAIO	122	150	40	4	10,91
PT09105	ACCIAIO	122	180	40	4	13,10
PT09106	ACCIAIO	122	200	40	4	14,55
PT09107	ACCIAIO	122	230	40	4	16,73
PT09108	ACCIAIO	137	60	40	4	5,80
PT09109	ACCIAIO	137	100	40	4	9,67
PT09110	ACCIAIO	137	130	40	4	12,57
PT09111	ACCIAIO	137	150	40	4	14,50
PT09112	ACCIAIO	137	180	40	4	17,41
PT09113	ACCIAIO	137	200	40	4	19,34
PT09114	ACCIAIO	137	230	40	4	22,24
PT09115	ACCIAIO	152	60	40	6	7,13
PT09116	ACCIAIO	152	100	40	6	11,89
PT09117	ACCIAIO	152	130	40	6	15,45
PT09118	ACCIAIO	152	150	40	6	17,83
PT09119	ACCIAIO	152	180	40	6	21,39
PT09120	ACCIAIO	152	200	40	6	23,77
PT09121	ACCIAIO	152	230	40	6	27,34
PT09122	ACCIAIO	160	60	40	8	7,74
PT09123	ACCIAIO	160	100	40	8	12,89
PT09124	ACCIAIO	160	130	40	8	16,76
PT09125	ACCIAIO	160	150	40	8	19,34
PT09126	ACCIAIO	160	180	40	8	23,21
PT09127	ACCIAIO	160	200	40	8	25,79
PT09128	ACCIAIO	160	230	40	8	29,65

DISTINTA BASE / Bill of Materials										
DESCRIZIONE DESCRIPTION	DIMENSIONI mm	CODICE CODE	CODICE PT091							
			01-08	02-09	03-10	04-11	05-12	06-13	07-14	
Cuneo / Wedge	58 x 24 x 10	CU133	4	/	/	/	/	/	/	/
Cuneo / Wedge	98 x 24 x 10	CU135	/	4	/	/	/	/	/	/
Cuneo / Wedge	128 x 24 x 10	CU136	/	/	4	/	/	/	/	/
Cuneo / Wedge	148 x 24 x 10	CU137	/	/	/	4	/	/	/	/
Cuneo / Wedge	178 x 24 x 10	CU139	/	/	/	/	4	/	/	/
Cuneo / Wedge	198 x 24 x 10	CU140	/	/	/	/	/	4	/	/
Cuneo / Wedge	228 x 24 x 10	CU142	/	/	/	/	/	/	4	/
Vite per Cuneo / Wedge's Screw	M10 x 20	VT022	8	8	12	12	16	16	20	
Chiave per Cuneo / Wedge's key	Esagonale 5	CH005	1	1	1	1	1	1	1	1
Chiave per Sfiato / Exhaust Screw's Key	Esagonale 3	CH003	1	1	1	1	1	1	1	1

DISTINTA BASE / Bill of Materials																
DESCRIZIONE DESCRIPTION	DIMENSIONI mm	CODICE CODE	CODICE PT091													
			15	16	17	18	19	20	21	22	23	24	25	26	27	28
Cuneo / Wedge	58 x 24 x 10	CU133	6	/	/	/	/	/	/	8	/	/	/	/	/	/
Cuneo / Wedge	98 x 24 x 10	CU135	/	6	/	/	/	/	/	/	8	/	/	/	/	/
Cuneo / Wedge	128 x 24 x 10	CU136	/	/	6	/	/	/	/	/	/	8	/	/	/	/
Cuneo / Wedge	148 x 24 x 10	CU137	/	/	/	6	/	/	/	/	/	/	8	/	/	/
Cuneo / Wedge	178 x 24 x 10	CU139	/	/	/	/	6	/	/	/	/	/	/	8	/	/
Cuneo / Wedge	198 x 24 x 10	CU140	/	/	/	/	/	6	/	/	/	/	/	/	8	/
Cuneo / Wedge	228 x 24 x 10	CU142	/	/	/	/	/	/	6	/	/	/	/	/	/	8
Vite per Cuneo / Wedge's Screw	M10 x 20	VT022	12	18	24	24	30	30	36	16	24	32	32	40	40	48
Chiave per Cuneo / Wedge's Key	Esagonale 5	CH005	1	1	1	1	1	1	1	1	1	1	1	1	1	1
Chiave per Sfiato / Exhaust Screw's Key	Esagonale 3	CH003	1	1	1	1	1	1	1	1	1	1	1	1	1	1

### COLTELLI ORDINABILI / Knives to be ordered

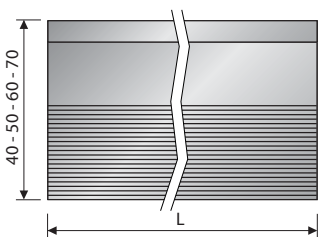

**CR**

Vedi pag. 393 / see page 393

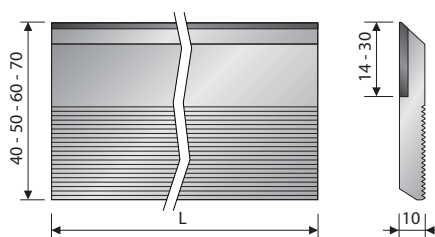

**CRW**

Vedi pag. 394 / see page 394

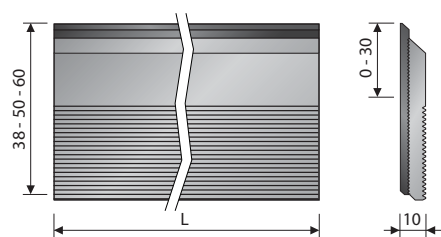

**Super Pack**

Vedi pag. 395 / see page 395

