



TESTA SPECIALE PER COLTELLI A GETTARE

Special cutterhead for disposable knives
Sonder Messerkopf für Einwegmesser
Cabezal especial para cuchillas de usar y tirar

*** DIAMETRO DEL FORO A RICHIESTA**

Bore's diameter on request
Bohrungs durchmesser nach anfrage
Diámetro de eje sobre pedido a pedir a parte



CODICE CODE	MATERIALE MATERIAL	D mm	B mm	d mm	Z
GT13001	ACCIAIO	140	20	*	4
GT13002	ACCIAIO	160	20	*	4
GT13003	ACCIAIO	200	20	*	4
GT13004	ACCIAIO	250	20	*	4
GT13005	ACCIAIO	300	20	*	4
GT13006	ACCIAIO	140	30	*	4
GT13007	ACCIAIO	160	30	*	4
GT13008	ACCIAIO	200	30	*	4
GT13009	ACCIAIO	250	30	*	4
GT13010	ACCIAIO	300	30	*	4
GT13011	ACCIAIO	140	50	*	4
GT13012	ACCIAIO	160	50	*	4
GT13013	ACCIAIO	200	50	*	4
GT13014	ACCIAIO	250	50	*	4
GT13015	ACCIAIO	300	50	*	4
GT13016	ACCIAIO	140	60	*	4
GT13017	ACCIAIO	160	60	*	4
GT13018	ACCIAIO	200	60	*	4
GT13019	ACCIAIO	250	60	*	4
GT13020	ACCIAIO	300	60	*	4

PER LAVORAZIONI AGGIUNTIVE VEDI PAG. 182
For additional works see page 182
Für zusätzliche bearbeitungen s. seite 182
Por trabajos añadidos ves pág. 182

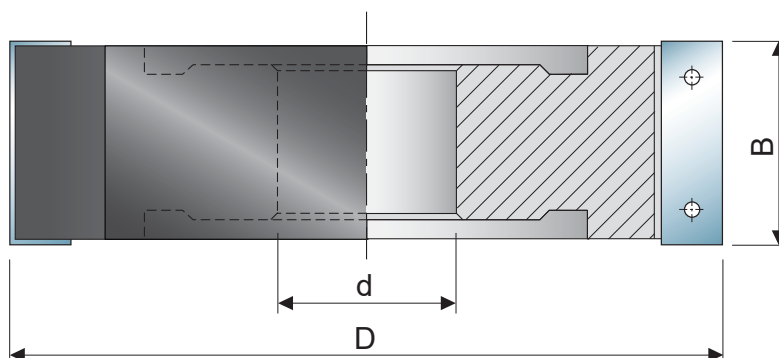

DISTINTA BASE / Bill of Materials						
DESCRIZIONE DESCRIPTION	DIMENSIONI <i>mm</i>	CODICE CODE	CODICE GT130			
			01/05	06/10	11/15	16/20
Coltello / Knife	20 x 12 x 1,5	CGZ207	4	/	/	/
Coltello / Knife	30 x 12 x 1,5	CGZ211	/	4	/	/
Coltello / Knife	50 x 12 x 1,5	CGZ215	/	/	4	/
Coltello / Knife	60 x 12 x 1,5	CGZ217	/	/	/	4
Cuneo / Wedge	16 x 15 x 8	CU001	4	/	/	/
Cuneo / Wedge	26 x 15 x 8	CU002	/	4	/	/
Cuneo / Wedge	46 x 15 x 8	CU095	/	/	4	/
Cuneo / Wedge	56 x 15 x 8	CU100	/	/	/	4
Ogiva / Nut	Ø13 x 9	OG001	4	4	8	8
Vite per Ogiva / Nut's Screw	M8 x 22	VT001	4	4	8	8
Chiave per Ogive / Nut's Key	Esagonale 4	CH004	1	1	1	1

ESEMPI DI LAVORAZIONE

Working Example

