

GRUPPO PER PARQUETS E PERLINE

Tool's set for parquets and matchboards
Werkzeugsatz für Parquets und Spundbretten
Cabezal para parqués y listones



CODICE CODE	MATERIALE MATERIAL	D mm	B mm	d mm	Z	R	S
GT10001	ACCIAIO	149	20	50	4	2	/
GT10002	ACCIAIO	137	7,5	50	/	/	2 + 2
GT10003	ACCIAIO	149	20	50	4	2	/
GT10004	ACCIAIO	136	20	50	4	/	2
GT10005	ACCIAIO	150	4 ÷ 7,5	50	4 + 4	2 + 2	/
GT10006	ACCIAIO	136	20	50	4	/	2
GT10007	ACCIAIO	150	20	50	4	2	/
GT10008	ACCIAIO	163	12	50	4	/	/
GT10009	ACCIAIO	150	12	50	4	/	/
GT10010	ACCIAIO	163	12	50	4	/	/
GT10011	ACCIAIO	150	12	50	4	/	/
GT10012	ACCIAIO	140	20	50	4	2	/
GT10013	ACCIAIO	122	7,5	50	/	/	2 + 2
GT10014	ACCIAIO	152	12	50	4	2	/
GT10015	ACCIAIO	130	20	50	4	/	/
GT10016	ACCIAIO	142	12	50	4	/	/
GT10017	ACCIAIO	166	12	50	4	2	/
GT10018	ACCIAIO	147	12	50	4	/	/

DISTINTA BASE / Bill of Materials

DESCRIZIONE DESCRIPTION	DIMENSIONI mm	CODICE CODE	CODICE GT100							
			01/03/07/12	02/13	04/06	05	08/09/10/11	14/17	15	16/18
Coltello / Knife	18 x 18 x 1,95	IPCZ401	/	/	/	8	/	/	/	/
Coltello / Knife	12 x 12 x 1,5	CGZ203	/	/	/	/	4	4	/	4
Coltello / Knife	20 x 12 x 1,5	CGZ207	4	/	4	/	/	/	4	/
Rasante / Spur	14 x 14 x 2	RAS02	2	/	/	/	/	/	/	/
Rasante / Spur	14 x 14 x 1,2	RAS04	/	/	/	4	/	/	/	/
Rasante / Spur	22 x 19 x 2	RAS06	/	/	/	/	/	2	/	/
Inserto Smuss. / Beveling Insert	22 x 16 x 5 45°	SPF01	/	/	2	/	/	/	/	/
Inserto Ragg. / Rounding Insert	22 x 16 x 5 R2	SPF03	/	4	/	/	/	/	/	/
Cuneo / Wedge	16 x 15 x 8	CU001	4	/	4	/	/	/	4	/
Cuneo / Wedge	10 x 12 x 10	CU009	/	/	/	/	/	4	/	4
Ogiva / Nut	Ø13 x 9	OG001	4	/	4	/	/	/	4	/
Vite per Cuneo / Wedge's Screw	M8 x 16	VT005	/	/	/	/	/	4	/	4
Vite per Ogiva / Nut's Screw	M8 x 22	VT001	4	/	4	/	/	/	4	/
Vite per Coltello / Knife's Screw	M4 x 8 Ø9	VT013	/	/	/	/	4	/	/	/
Vite per Rasante / Spur's Screw	M5 x 6,5 Ø9	VT064	2	/	/	/	/	2	/	/
Vite per Coltello / Knife's Screw	M4 x 3 Ø6	VT007	/	/	/	12	/	/	/	/
Viti per Inserto / Insert's Screw	M5 x 10 Ø10	VT003	/	4	2	/	/	/	/	/
Ghiera per Ras. / Spur's Threaded rings	Ø9,9 M4x1,2	GH001	/	/	/	4	/	/	/	/
Ghiera per Colt. / Knife's Threaded rings	Ø11,8 M4x1,5	GH002	/	/	/	8	/	/	/	/
Set Anelli / Set Rings	d50 x 3,8	SA005	/	/	/	1	/	/	/	/
Chiave per Coltello / Knife's Key	Esagonale 3	CH003	/	1	1	/	/	/	/	/
Chiave per Coltello / Knife's Key	Torx 15	TK015	/	/	/	/	1	/	/	/
Chiave per Rasante / Spur's Key	Torx 20	TK020	1	/	/	/	/	1	/	/
Chiave per Ogiva / Nut's Key	Esagonale 4	CH004	1	/	1	/	/	1	1	1

PROFILI REALIZZABILI
Example of Profiles

GRUPPO 1
Cutterhead set 1

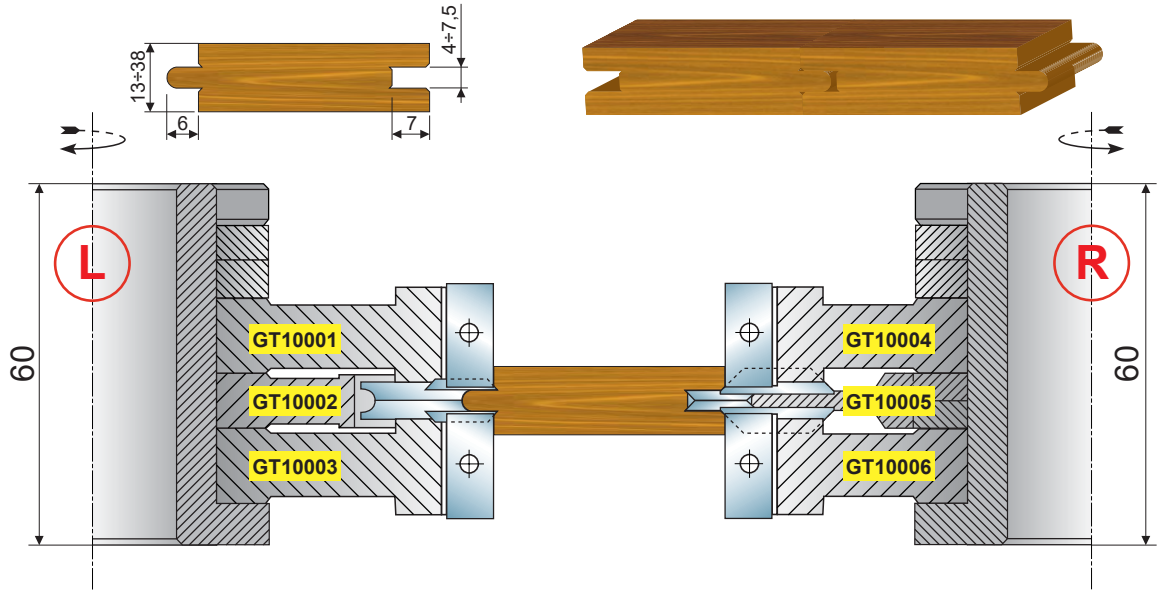

GRUPPO 2
Cutterhead set 2

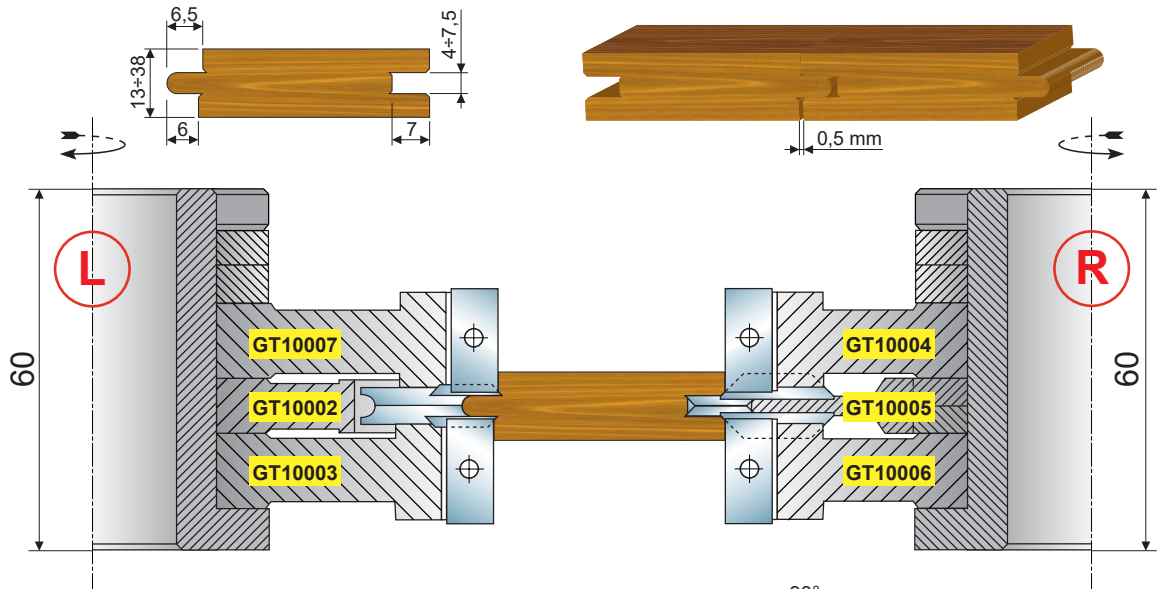

GRUPPO 3
Cutterhead set 3

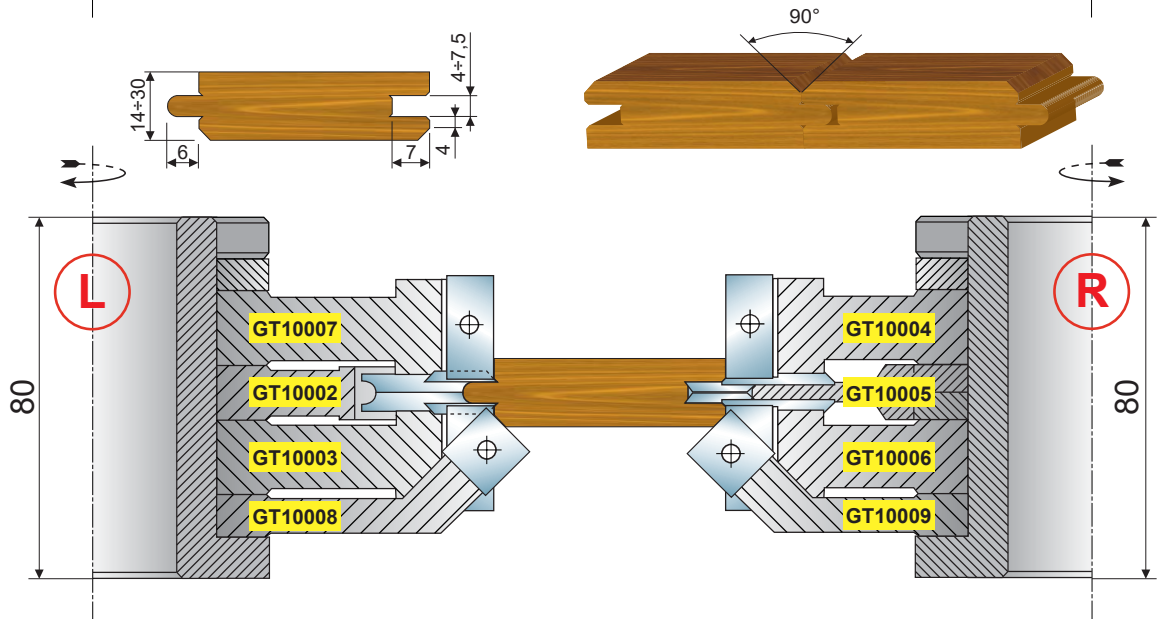

LE BOCCOLE E GLI ANELLI DISTANZIALI SONO DA ORDINARE SEPARATAMENTE, VEDI PAG. 402

The sleeves and the spacer rings must be ordered separately; see page 402

Die Büchsen und die Zwischenringe sind separat zu bestellen, s. seite 402

Los casquillos y los anillos distanciadores son a pedir a parte, ves pág. 402

PROFILI REALIZZABILI

Example of Profiles

GRUPPO 4
Cutterhead set 4

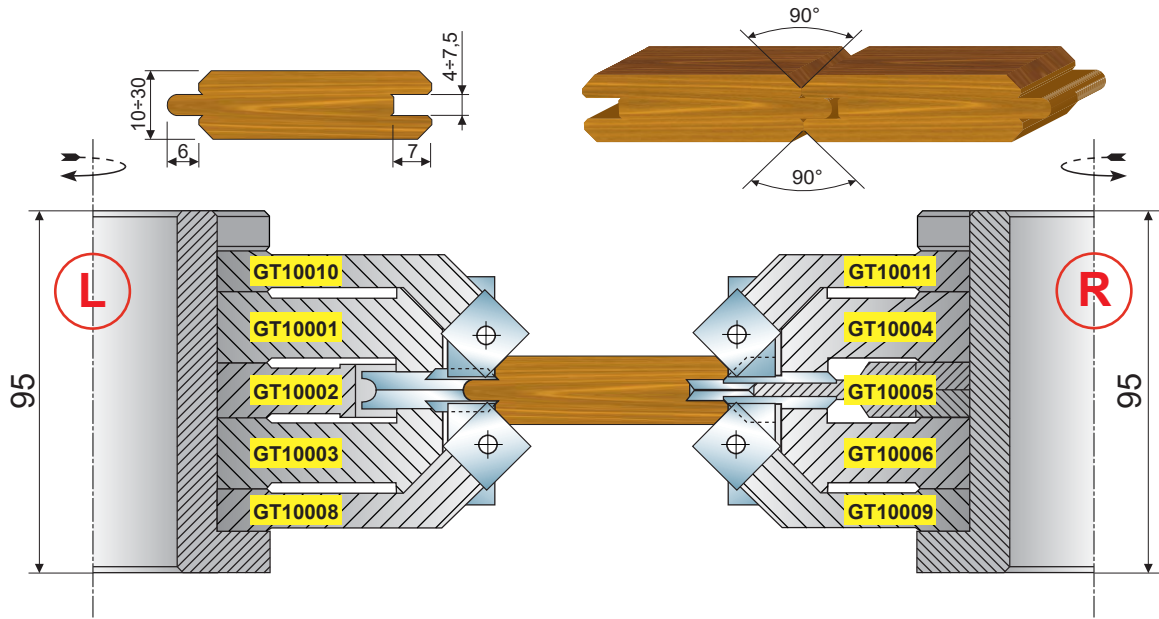

GRUPPO 5
Cutterhead set 5

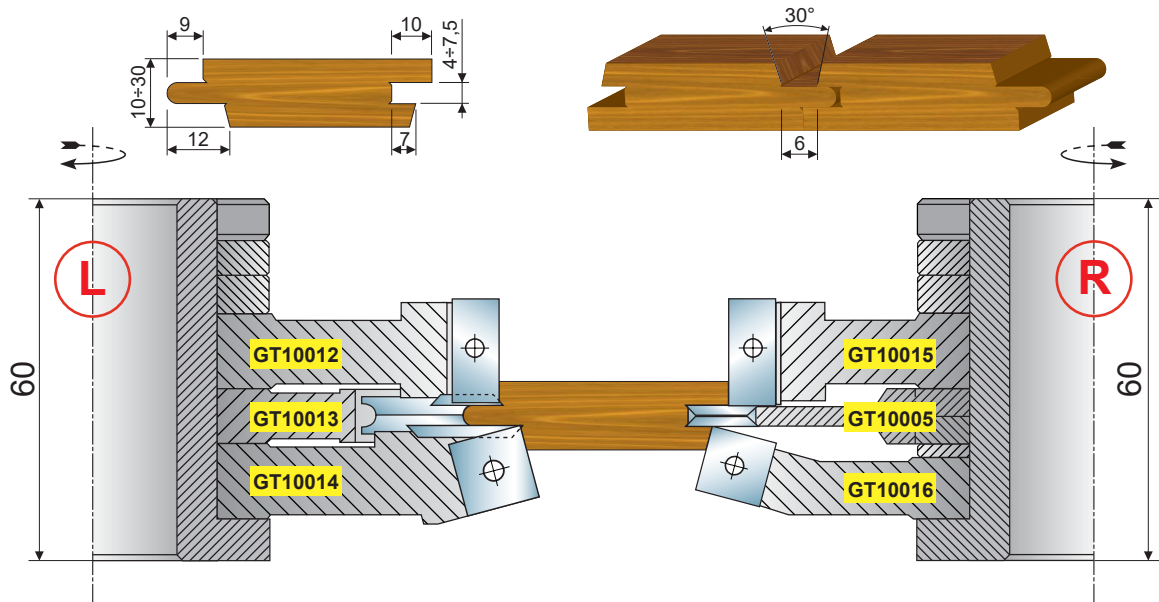

GRUPPO 6
Cutterhead set 6

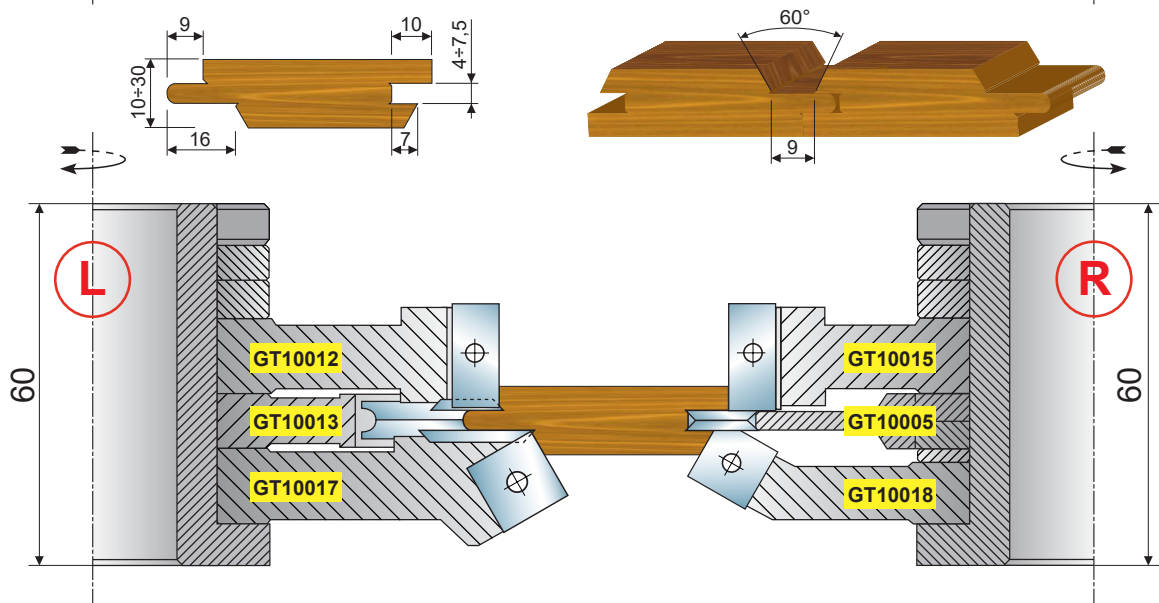

LE BOCCOLE E GLI ANELLI DISTANZIALI SONO DA ORDINARE SEPARATAMENTE, VEDI PAG. 402

The sleeves and the spacer rings must be ordered separately; see page 402

Die Büchsen und die Zwischenringe sind separat zu bestellen, s. seite 402

Los casquillos y los anillos distanciadores son a pedir a parte, ves pág. 402