



TESTA PER QUARTO DI TONDO - RAGGIO MEDIO

Head for a quarter of a round - Medium radius
 Viertelkreisfräser - Mittel-Radius
 Cabezal para cuarto de redondo - Radio medio

CODICE CODE	MATERIALE MATERIAL	D mm	B mm	d mm	Z	ROTAZ. ROTAT.	KIT
GT01201	ACCIAIO	160	30	35 / 40	3	R	
GT01202	ACCIAIO	160	30	35 / 40	3	L	
GT01203	ACCIAIO	160	30	35 / 40	3	R + L	*

* **COMPRENDE UN SET DI COLTELLI
CON RAGGI: 14 - 15 - 16**
 Knives' set with 14-15-16 radius included
 Messerset mit Radius 14-15-16 inklusive
 Set de cuchillas con radio 14-15-16 incluidos

DISTINTA BASE / Bill of Materials						
DESCRIZIONE DESCRIPTION	DIMENSIONI mm	CODICE CODE	CODICE GT012			
			01	02	03	
Coltello / Knife	30 x 25 x 2 R14	CRR04	/	/	6	
Coltello / Knife	30 x 25 x 2 R15	CRR05	/	/	6	
Coltello / Knife	30 x 25 x 2 R16	CRR06	/	/	6	
Cuneo / Wedge	18 x 28 x 8	CU125	3	3	6	
Ogiva / Nut	Ø13 x 9	OG001	3	3	6	
Vite per Ogiva / Nut's Screw	M8 x 22	VT001	3	3	6	
Vite di riferimento / Positioning Screw	M5 x 7 Ø16	VT012	3	3	6	
Set Anelli / Set Rings	d35/40 x 39	SA020	/	/	1	
Chiave per Coltello / Knife's Key	Esagonale 4	CH004	1	1	1	
Valigetta / Handbag		VAL01	/	/	1	

ESEMPI DI LAVORAZIONE Working Example

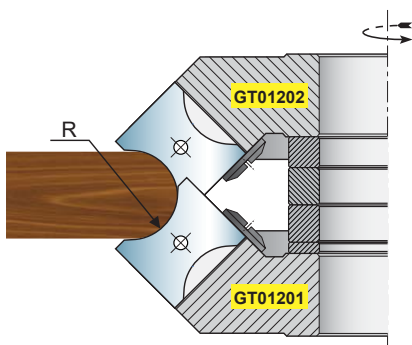
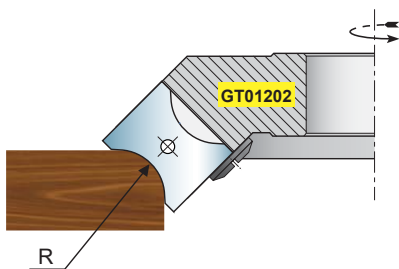

ANELLI DISTANZIALI FORNITI IN BASE AL DIAMETRO DEL FORO
 Spacer rings are supplied based on hole diameter
 Zwischenringe sind nach dem Bohrungsdurchmesser geliefert
 Anillos distanciadores incluidos en función del diámetro del eje

COLTELLI CON RAGGI INTERMEDI A RICHIESTA
 Knives with intermediate radius on request
 Messer mit Zwischenradius auf Anfrage
 Cuchillas con radios intermedio a petición

