

TESTA PER QUARTO DI TONDO - RAGGIO PICCOLO

Head for quarter of a round - Small radius

Viertelkreisfräser - Kleiner Radius

Cabezal para cuarto de redondo - Radio pequeño



CODICE CODE	MATERIALE MATERIAL	D / D ₁ mm	B mm	d mm	Z	ROTAZ. ROTAT.	KIT
GT01001	ACCIAIO	149 / 125	20	35 / 40	3	R	
GT01002	ACCIAIO	149 / 125	20	35 / 40	3	L	
GT01003	ACCIAIO	149 / 125	20	35 / 40	3	R + L	*

* **COMPRENDE UN SET DI COLTELLI CON RAGGI: 5 - 6 - 8**
Knives' set with 5-6-8 radius included
Messerset mit Radius 5-6-8 inklusive
Set de cuchillas con radio 5-6-8 incluidos

DISTINTA BASE / Bill of Materials						
DESCRIZIONE DESCRIPTION	DIMENSIONI mm	CODICE CODE	CODICE GT010			
			01	02	03	
Coltello / Knife	20 x 21 x 2 R5	CRR01	/	/	6	
Coltello / Knife	20 x 21 x 2 R6	CRR02	/	/	6	
Coltello / Knife	20 x 21 x 2 R8	CRR03	/	/	6	
Cuneo / Wedge	18 x 15 x 8	CU124	3	3	6	
Ogiva / Nut	Ø13 x 9	OG001	3	3	6	
Vite per Ogiva / Nut's Screw	M8 x 22	VT001	3	3	6	
Vite di riferimento / Positioning Screw	M5 x 7 Ø16	VT012	3	3	6	
Set Anelli / Set Rings	d35/40 x 30	SA019	/	/	1	
Chiave per Coltello / Knife's Key	Esagonale 4	CH004	1	1	1	
Valigetta / Handbag		VAL01	/	/	1	

ESEMPI DI LAVORAZIONE Working Example

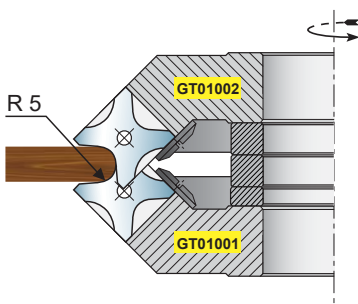
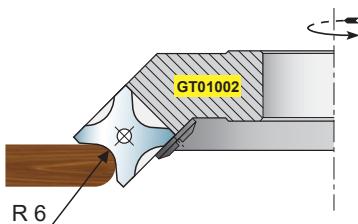

ANELLI DISTANZIALI FORNITI IN BASE AL DIAMETRO DEL FORO
Spacer rings are supplied based on hole diameter
Zwischenringe sind nach dem Bohrungsdurchmesser geliefert
Anillos distanciadores incluidos en función del diámetro del eje

COLTELLI CON RAGGI INTERMEDI A RICHIESTA
Knives with intermediate radius on request
Messer mit Zwischenradius auf Anfrage
Cuchillas con radios intermedio a petición

