

FRESA PER CONTORNARE E SPIANARE - GRANDI ASPORTAZIONI

Cutter for sizing and planing - Big removal

Fräser für ausschneiden und spannen - Große Materialabtrag

Fresa para contornar y allanar - Grande extracción

GLI ATTACCHI PER I CORPI IN LEGA LEGGERA SONO DA ORDINARE A PARTE
The toolholders for the bodies in light alloy must be ordered separately
Die Aufnahmen für die Körper aus Leichtmetall sind separat zu bestellen
Las portaherramientas para cuerpos en aleación ligera son a pedir a parte

Vedi pag. 407 - see page 407 - siehe Seite 407 - véase página 407

CODICE CODE	MATERIALE MATERIAL	D mm	B mm	Lt mm	ATTACCO / SHANK		Z
					d mm	l mm	
GP09001	ACCIAIO	50	62	121	20	50	2 + 2
GP09002	ACCIAIO	50	74	133	20	50	2 + 2
GP09003	ACCIAIO	50	86	145	20	50	2 + 2
GP09004	LEGA LEGG.*	80	62	/	25	/	2 + 2
GP09005	LEGA LEGG.*	80	74	/	25	/	2 + 2
GP09006	LEGA LEGG.*	80	86	/	25	/	2 + 2

ESEMPI DI LAVORAZIONE Working Example

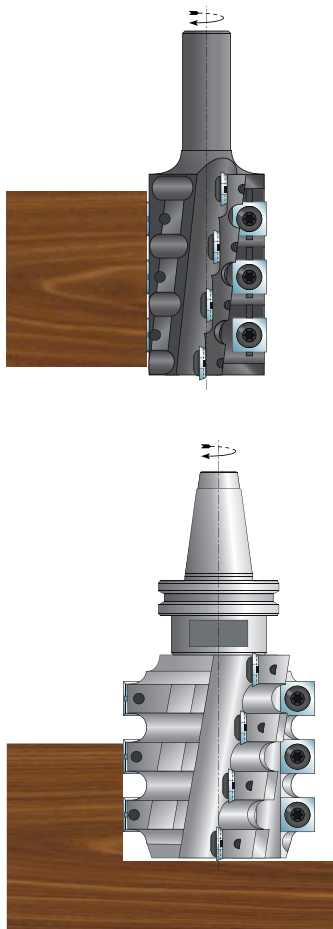

DISTINTA BASE / Bill of Materials								
DESCRIZIONE DESCRIPTION	DIMENSIONI mm	CODICE CODE	CODICE GP090					
			01	02	03	04	05	06
Coltello / Knife	14,3 x 14,3 x 2,8	CRC01	10	14	18	10	14	18
Vite per Coltello / Knife's Screw	M5 x 10,2 Ø10,5	VT004	10	14	18	10	14	18
Chiave per Coltello / Knife's Key	Torx 20	TK020	1	1	1	1	1	1

*** CORPO IN LEGA LEGGERA, NON USARE SODA CAUSTICA.**
Body in a light alloy, do not use caustic soda.
Körper aus Leichtmetall-Legierung, kein Ätznatron verwenden.
Cuerpo en aleación ligera, no utilizar sosa cáustica.

ATTACCO PER CODICE GP090 Shank for code GP090

