



MOZZO SPECIALE PER FRESE REGOLABILI

Special hub for adjustable cutterheads
Sonder Nabe für verstellbare Fräser
Buje especial para fresas regulables

Foto dimostrativa.

La fresa non è compresa nel prezzo

Indicate photo, cutter non included in the price
Indikativ Foto Fräser nicht im Preis inbegriffen
Foto indicativo, cabezal no incluido en el precio

DAF14501

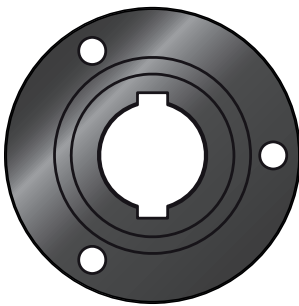

DAF14502

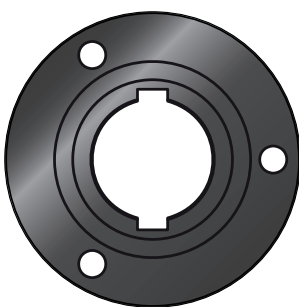

DAF14503



CODICE CODE	MATERIALE MATERIAL	D mm	D ₁ mm	H mm	B mm	d mm	DKN mm
DAF14501	ACCIAIO	98	65	98	24÷38	35	2 - 10 X 3,3
DAF14502	ACCIAIO	98	65	98	24÷38	40	2 - 10 X 3,3
DAF14503	ACCIAIO	98	65	98	24÷38	40	ESAGONO

DISTINTA BASE / Bill of Materials						
DESCRIZIONE DESCRIPTION	DIMENSIONI mm	CODICE CODE	CODICE DAF145			
			01	02	03	
Boccola Hydro / Hydro sleeve	Ø98/65 L55	BHY04	1	1	1	
Boccola / sleeve	Ø65/35 DKN L98	BHY05	1	/	/	
Boccola / sleeve	Ø65/40 DKN L98	BHY06	/	1	/	
Boccola / sleeve	Ø65/40 HEX L98	BHY07	/	/	1	
Anello Distanziale / Spacer ring	Ø98/65 x 22	A070	1	1	1	
Spina di Trasc. / Nut	Ø12 x 32	VT060	3	3	3	
Vite per Fresa / Wedge's Screw	M8 x 54 Ø13	VT061	3	3	3	
Vite per Fresa / Wedge's Screw	M8 x 22 Ø13	VT062	3	3	3	
Vite per Spina / Wedge's Screw	M8 x 16 Ø12	VT063	3	3	3	
Chiave di Reg. / Adjustment Key	Esagonale 6	CH006	1	1	1	

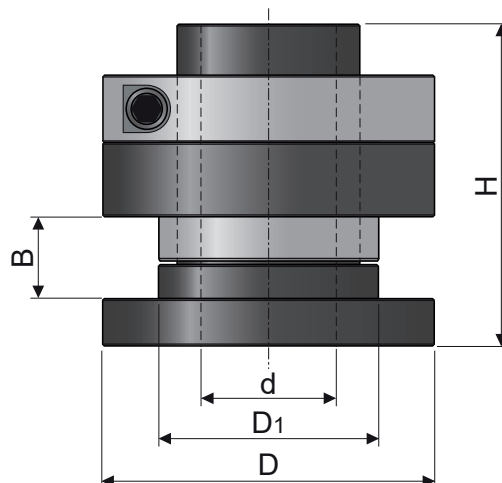

Le frese regolabili montate su questo mozzo possono essere regolate mediante una chiave di regolazione senza dover smontare l'utensile per inserire gli anelli distanziali

On this hub you can adjust the cutterhead with a key, without disassembling it and putting the distance rings inside

Auf diese Nabe kann man die Fräser mit einer Schraube verstellen ohne die Fräser auszubauen um die Distanzringe einzufügen

Las fresas montadas su este buje pueden ser reguladas por medio de una llave sin desmontar la fresa para introducir los anillos distanciadores

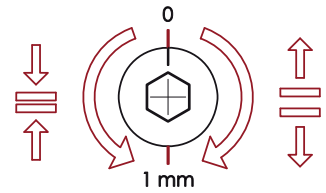

- 1 GIRO = 2 mm
- 1 TURN = 2 mm
- 1 UMDREHUNG = 2 mm
- 1 VUELTA = 2 mm

APERTO

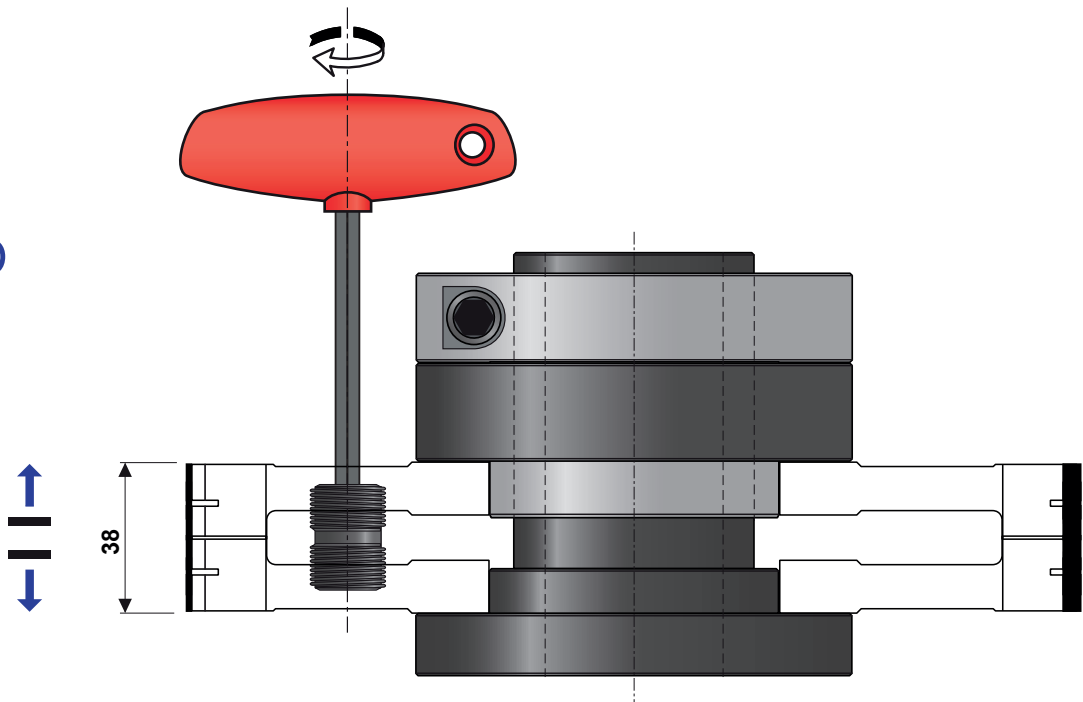

CHIUSO

