

GRUPPO DI 4 TESTE PER L'ESECUZIONE DI VARI PROFILI

Tools' set of 4 heads for different profiles
Werkzeugsatz (4 Köpfe) für verschiedene Profilen
Grupo de 4 cabezales para varios perfiles

CODICE CODE	MATERIALE MATERIAL	D mm	B mm	d mm	Z	KIT
AT10001	ACCIAIO	154	50	35	2	
AT10002	ACCIAIO	169	40	35	2	
AT10003	ACCIAIO	113	45	35	2	
AT10004	ACCIAIO	150	45	35	2	
AT10005	ACCIAIO	AT100 (01+02+03+04)				*

DISTINTA BASE / Bill of Materials							
DESCRIZIONE DESCRIPTION	DIMENSIONI mm	CODICE CODE	CODICE AT100				
			01	02	03	04	05
Coltello / Knife	50 x 30 x 3	CSAT149	2	/	/	/	2
Coltello / Knife	40 x 35 x 3	CSAT150	/	2	/	/	2
Coltello / Knife	45 x 25 x 3	CSAT151	/	/	2	/	2
Coltello / Knife	45 x 25 x 3	CSAT152	/	/	/	2	2
Cuneo / Wedge	48 x 20 x 8	CU107	2	/	/	/	2
Cuneo / Wedge	37 x 20 x 8	CU108	/	2	/	/	2
Cuneo / Wedge	43 x 15 x 8	CU109	/	/	2	/	2
Cuneo / Wedge	43 x 13,5 x 8	CU110	/	/	/	2	2
Vite per Cuneo / Wedge's Screw	M8 x 16	VT005	4	4	4	4	16
Vite di Riferimento / Positioning Screw	M5 x 7 Ø16	VT012	2	2	2	2	8
Set Anelli / Set Rings	Ø35 x 49	SA021	/	/	/	/	1
Chiave per Cuneo / Wedge's Key	Esagonale 4	CH004	1	1	1	1	1

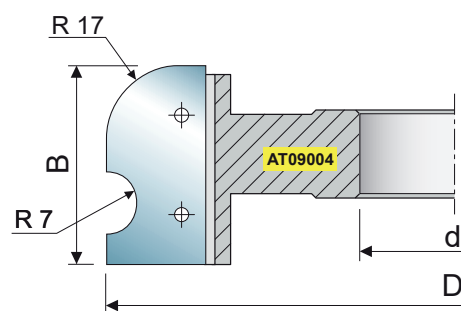
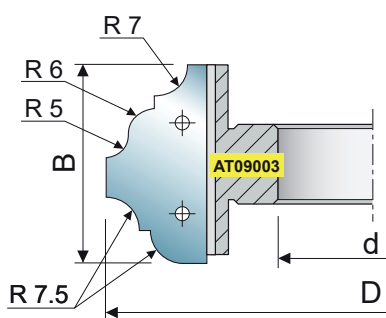
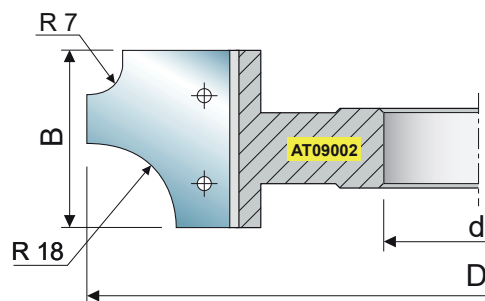
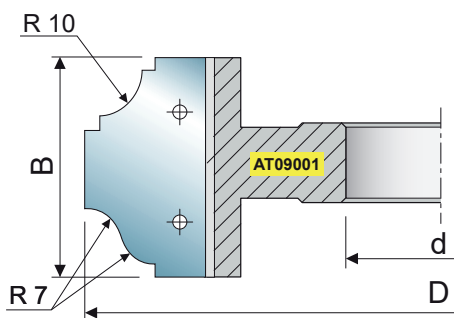

ESEMPI DI PROFILI
Example of Profile

