



FRESA MULTIPROFILO CON CON CONTROPLACCHE

Multi-profile cutter with counter plates

Multiprofilfräser mit Stütze

Fresa multiperfil con soporte

CODICE CODE	D min. mm	D max. mm	B mm	PP Max mm	ATTACCO / SHANK		Z	TIPO TYPE
					d mm	l mm		
AP15001	54	108	40	10 ÷ 25	20	50	2	1
AP15002	54	108	40	10 ÷ 25	20	50	2	2
AP15003	54	108	40	10 ÷ 25	20	50	2	3
AP15004	54	108	60	10 ÷ 25	20	50	2	1
AP15005	54	108	60	10 ÷ 25	20	50	2	2
AP15006	54	108	60	10 ÷ 25	20	50	2	3
AP15007	54	108	80	10 ÷ 25	20	50	2	1
AP15008	54	108	80	10 ÷ 25	20	50	2	2
AP15009	54	108	80	10 ÷ 25	20	50	2	3

DISTINTA BASE / Bill of Materials					
DESCRIZIONE DESCRIPTION	DIMENSIONI mm	CODICE CODE	CODICE AP150		
			01/02/03	04/05/06	07/08/09
Cuneo / Wedge	38 x 25 x 8	CU151	2	/	/
Cuneo / Wedge	58 x 25 x 8	CU152	/	2	/
Cuneo / Wedge	78 x 25 x 8	CU153	/	/	2
Vite per cuneo / Wedge's Screw	M8 x 16	VT005	4	4	6
Chiave per Cuneo / Wedge's Key	Esagonale 4	CH004	1	1	1

ATTENZIONE : I CUNEI VARIANO A SECONDA DEL TIPO DI AP150 (Es. TIPO 1, TIPO 2 o TIPO 3)

ATTENTION : Wedges vary according to the type of AP150 (e.g. TYPE 1, TYPE 2, TYPE 3)

ACHTUNG : Keile sind je nach AP150 typ unterschiedlich (z.b. TYP 1, TYP 2, TYP 3)

ATENCIÓN : Cuñas varían en función del tipo de AP150 (eg. TIPO 1, TIPO 2, TIPO 3)

TIPOLOGIA DI UTENSILE

Tool type

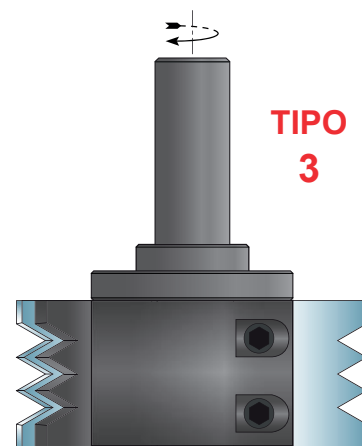
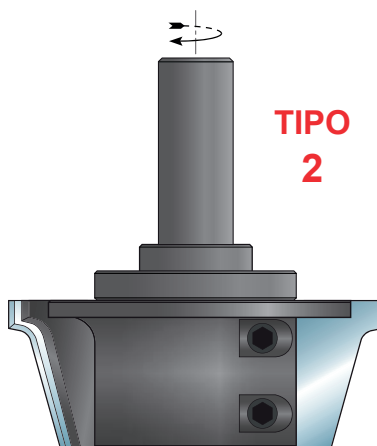
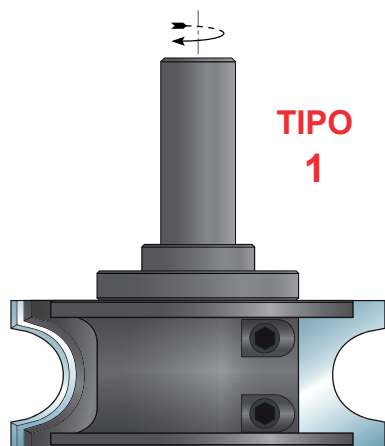

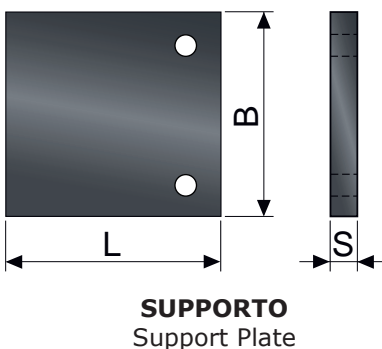
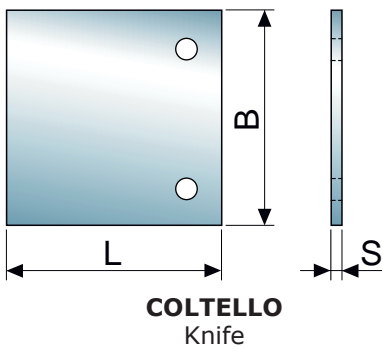

ESEMPI DI LAVORAZIONE
Working Example

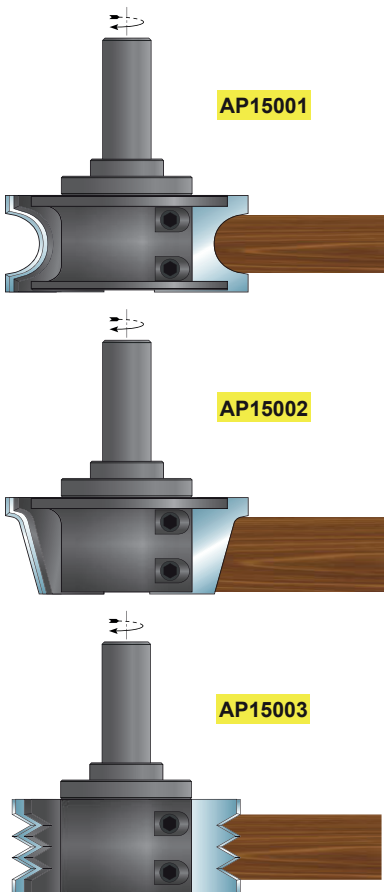

AREA PROFILABILE
Area to be profiled
Profilierbarer Bereich
Área a perfilar

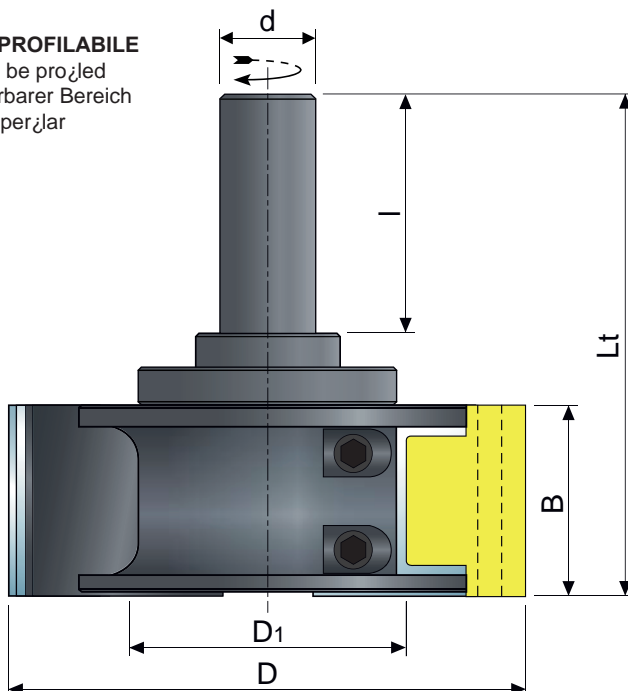

COLTELLI ORDINABILI / Order Knives					
DESCRIZIONE DESCRIPTION	B x L x S mm	CODICE CODE	CODICE AP150		
			01/02/03	04/05/06	07/08/09
Coltello / Knife	40 x 30 x 2	CSAP098	2	/	/
Coltello / Knife	40 x 35 x 2	CSAP099	2	/	/
Coltello / Knife	40 x 40 x 2	CSAP100	2	/	/
Coltello / Knife	40 x 45 x 2	CSAP101	2	/	/
Coltello / Knife	60 x 30 x 2	CSAP102	/	2	/
Coltello / Knife	60 x 35 x 2	CSAP103	/	2	/
Coltello / Knife	60 x 40 x 2	CSAP104	/	2	/
Coltello / Knife	60 x 45 x 2	CSAP105	/	2	/
Coltello / Knife	80 x 30 x 2	CSAP106	/	/	2
Coltello / Knife	80 x 35 x 2	CSAP107	/	/	2
Coltello / Knife	80 x 40 x 2	CSAP108	/	/	2
Coltello / Knife	80 x 45 x 2	CSAP109	/	/	2

SUPPORTI ORDINABILI / Order Support Plate					
DESCRIZIONE DESCRIPTION	B x L x S mm	CODICE CODE	CODICE AP150		
			01/02/03	04/05/06	07/08/09
Supporto / Support Plate	40 x 30 x 5	SU031	2	/	/
Supporto / Support Plate	40 x 35 x 5	SU032	2	/	/
Supporto / Support Plate	40 x 40 x 5	SU033	2	/	/
Supporto / Support Plate	40 x 45 x 5	SU034	2	/	/
Supporto / Support Plate	60 x 30 x 5	SU035	/	2	/
Supporto / Support Plate	60 x 35 x 5	SU036	/	2	/
Supporto / Support Plate	60 x 40 x 5	SU037	/	2	/
Supporto / Support Plate	60 x 45 x 5	SU038	/	2	/
Supporto / Support Plate	80 x 30 x 5	SU039	/	/	2
Supporto / Support Plate	80 x 35 x 5	SU040	/	/	2
Supporto / Support Plate	80 x 40 x 5	SU041	/	/	2
Supporto / Support Plate	80 x 45 x 5	SU042	/	/	2